

Pellet Heater

Self-Leveling Heated Dispenser

Specifications

- Electrical: 208/220 VAC, 60 Hz, single phase. Six foot grounded 20 amp power cord supplied.
- Option: Can be ordered in 240 VAC.
- Construction: The outer unit is constructed of 18 gauge stainless steel. Inner walls are constructed of .063 high strength aluminum. All sides and lids of unit are insulated with fiberglass insulation.
- Lids: Unique hat channel design requires no gaskets.
- Heating System: Thermostatically controlled, forced air heating system with 3200 watt element.
- Self-Leveling Dispenser: Individual, removable, self-adjusting and all stainless steel construction. Self-lubricating bearings ride over vertical guide rods. Available stacking height is 27 1/4".
- Casters: Unit is mounted on four 5" diameter swivel casters with non-marking cushion tread, two with swivel-lock and wheel brake.

ALLIANCE



1-800-522-3973



Pellet Heater

Self-Leveling Heated Dispenser

Dimensions

Model	Overall Size			Casters		Shipping Weight	Case Cube	Electrical Specifications			Thermostat Range
	W	D	H	Type	Dia.	lbs.	Cu. ft.	Watt	Amp	Volt	
DALPH1002	33 3/8"	23 3/4"	42 3/4"	4 swivel, 2 w/ brake	5"	270	24.0	3200	16.3 15	208/220 60 Hz 240	250 to 290 degrees Farenheit
DALPH1503	43 7/16"	23 3/4"	42 3/4"	4 swivel, 2 w/ brake	5"	335	31.1	3200	16.3 15	208/220 60 Hz 240	250 to 290 degrees Farenheit

Drawings

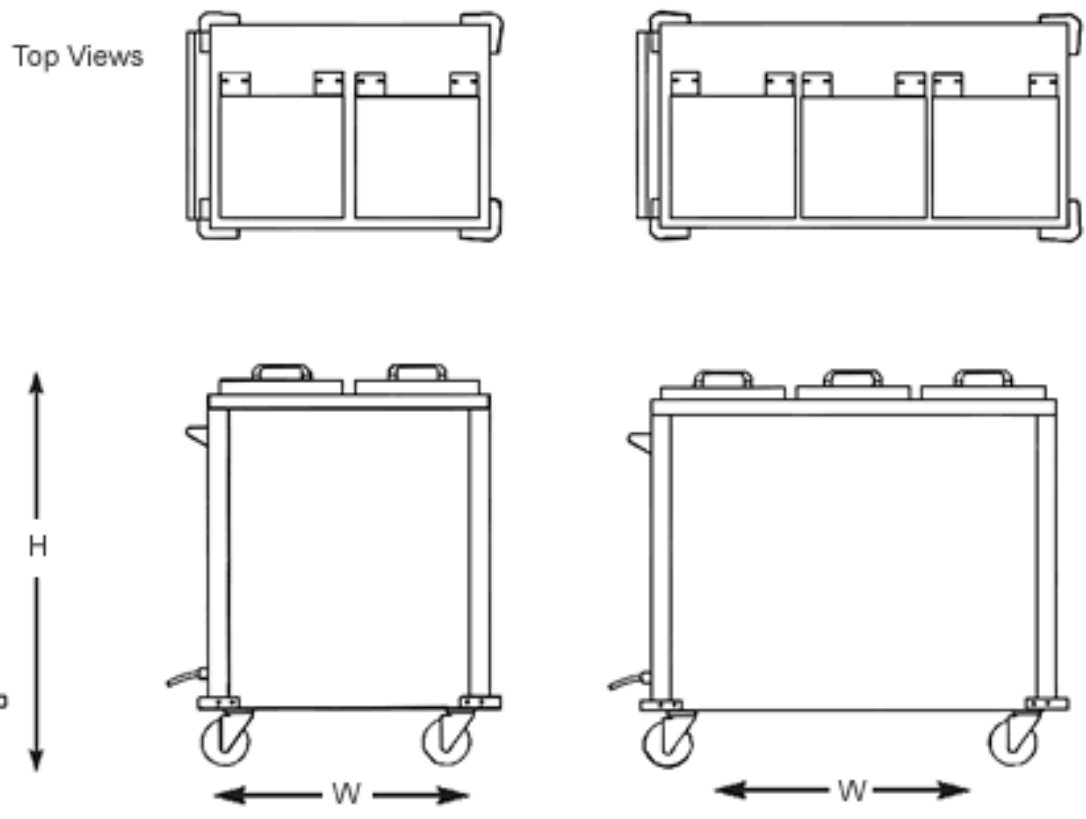

© 2008 Alliance Products, LLC
820 Esther Lane | Murfreesboro, TN 37129
1.800.522.3973 toll free
615.895.5333 phone
615.895.5334 fax