

# Combination Pellet and Plate Heater

The Deuce Self-Leveler

# ALLIANCE



1-800-522-3973

## Specifications

- The DALPH1022 has two heated compartments, one for plates and one for pellets, which are independently controlled and have an automatic hi-temp shut-off.
- Accommodates dishes and pellets ranging from 7" to 10 1/4"
- Electrical: 208/220 VAC, 60 Hz, single phase. Six foot grounded 20 amp power cord supplied.
- Option: Can be ordered in 240 VAC.
- Construction: The outer unit is constructed of 18 gauge stainless steel. Inner walls constructed of .063 high strength aluminum. All sides and lids of unit are insulated with fiberglass insulation.
- Lids: Unique hat-channel design requires no gaskets.
- Heating System: Thermostatically controlled-forced air heating system with 3200 watt element.
- Self-Leveling Dispenser: Individual, removable, self-adjusting and all stainless steel construction. Self-lubricating bearings ride over vertical guide rods. Available stacking height is 27 1/4".
- Casters: Unit is mounted on four 5" diameter swivel casters with non-marking cushion tread, two with swivel-lock and wheel with brakes.



# Combination Pellet and Plate Heater

The Deuce Self-Leveler

## Dimensions

Model	Overall Size			Casters		Shipping Weight	Case Cube	Electrical Specifications		
	W	D	H	Type	Dia.	lbs.	Cu. ft.	Watt	Amp	Volt
DALPH1022	36"	24"	42 3/4"	4 swivel, 2 w/brake	5"	285	32.7	3200	17.2	208/220 60 Hz

## Drawings

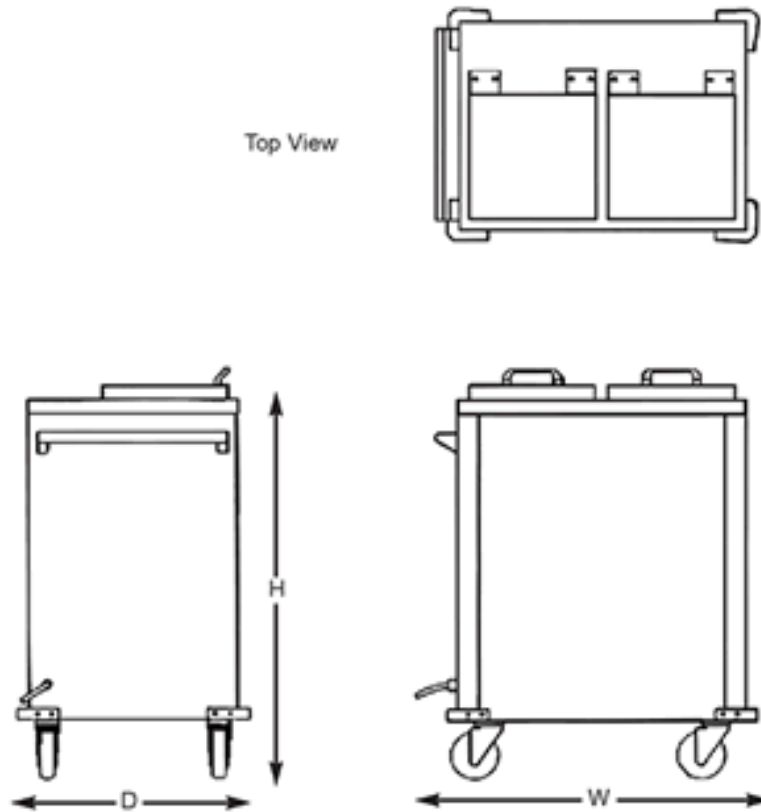

© 2008 Alliance Products, LLC  
820 Esther Lane | Murfreesboro, TN 37129  
1.800.522.3973 toll free  
615.895.5333 phone  
615.895.5334 fax